

Touch-Free Silver Dispenser Stand for Hand Sanitiser

PRODUCT DESCRIPTION

Stylish dispenser stands to promote hand sanitising.

SECTORS

- Office & Facility
- Healthcare
- Public Facilities
- Industrial
- Food
- Hospitality
- Education

TO BE USED WITH SC JOHNSON PROFESSIONAL TOUCH-FREE DISPENSERS:

- TF2WHI

STOCK CODE	COLOUR	QTY/CASE	INCLUDED DISPENSER
TFDISPSTAND	Silver	1	TF2WHI

FEATURES

Easy to assemble (only three main parts, assembly tools included)

Optional signage to customise the header with your message or logos (**template provided below**)

Sturdy metal construction

Durable coating to protect against wear & tear

Use included silver metal catch tray or black/white plastic catch trays (sold separately)

Low profile base to maximise stability

Lightweight and easy to carry when cleaning the facility

Comes with an SC Johnson Professional dispenser included



Dispenser included

TF Dispenser Stand Dimensions

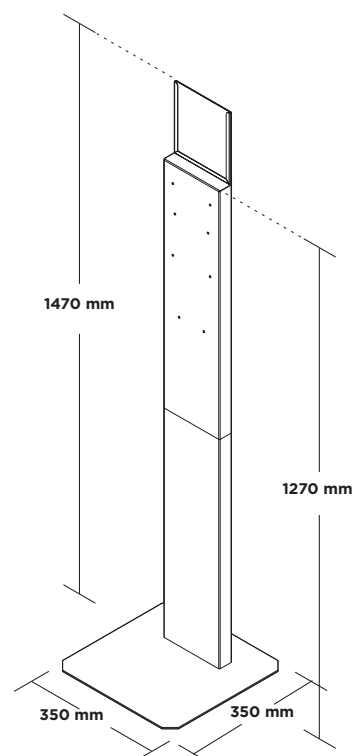

Touch-Free Silver Dispenser Stand for Hand Sanitiser

DESIGN YOUR OWN HEADER TEMPLATE

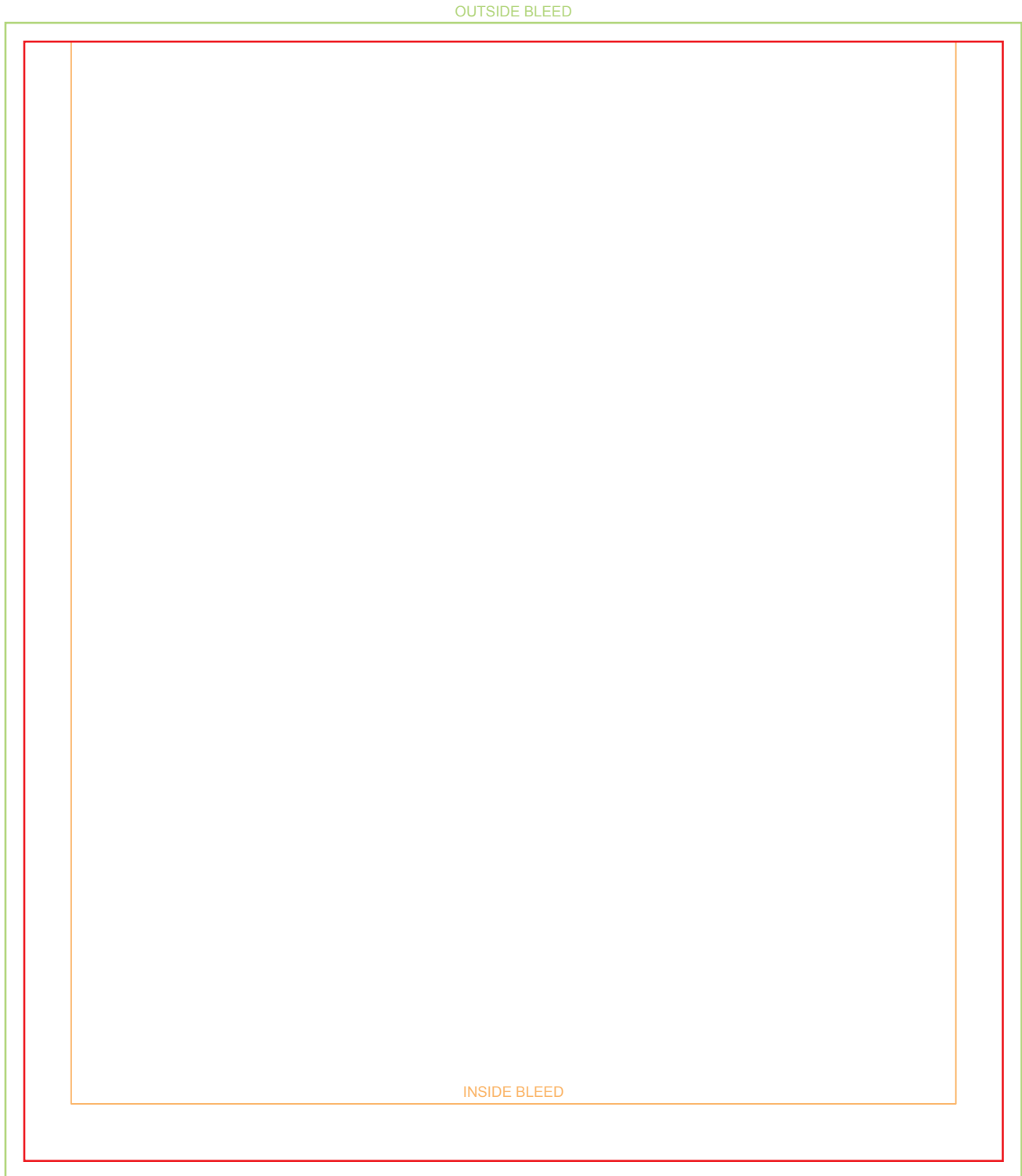

PRINT AREA :	171.45mm X 195.28mm
TRIM/DIE SIZE :	165.10mm X 188.93mm
SUBSTRATE :	0,25mm GLOSS LITHO STOCK

Touch-Free Silver Dispenser Stand for Hand Sanitiser

SANITISING STATION ASSEMBLY INSTRUCTIONS

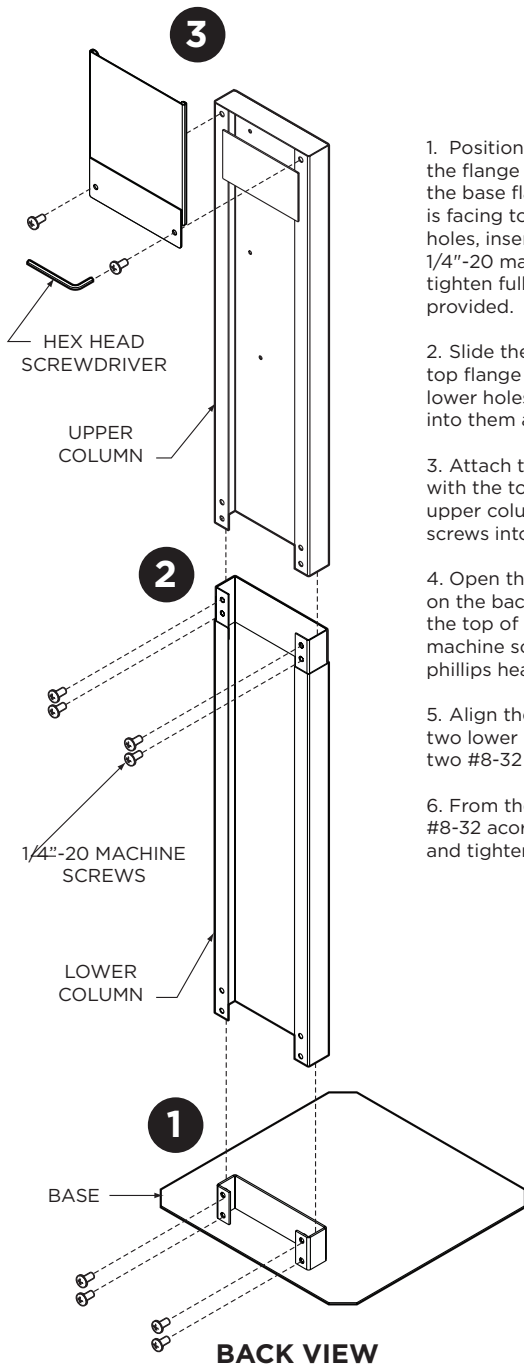
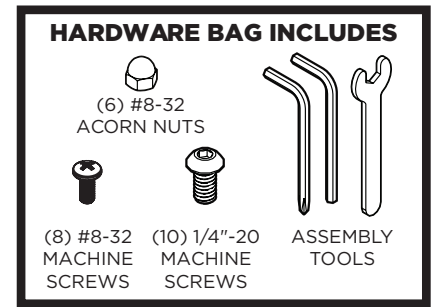

1. Position the base in the desired location with the flange side up. Slide the lower column over the base flange so the open face of the column is facing towards the back. Align the four lower holes, insert four 1/4"-20 machine screws into them and tighten fully using the hex head assembly tool provided.

2. Slide the open end of upper column over the top flange of the lower column. Align the four lower holes, insert four 1/4"-20 machine screws into them and tighten fully.

3. Attach the header by aligning its two holes with the top two holes on the back of the upper column. Insert two 1/4"-20 machine screws into them and tighten fully.

4. Open the dispenser. Align the top four holes on the backplate with the top four holes at the top of the upper column, insert four #8-32 machine screws and tighten fully with the phillips head assembly tool provided.

5. Align the two holes in the drip tray with the two lower holes on the upper column, insert two #8-32 machine screws.

6. From the back of the unit, attach the #8-32 acorn nuts to the #8-32 machine screws and tighten down with the wrench provided.

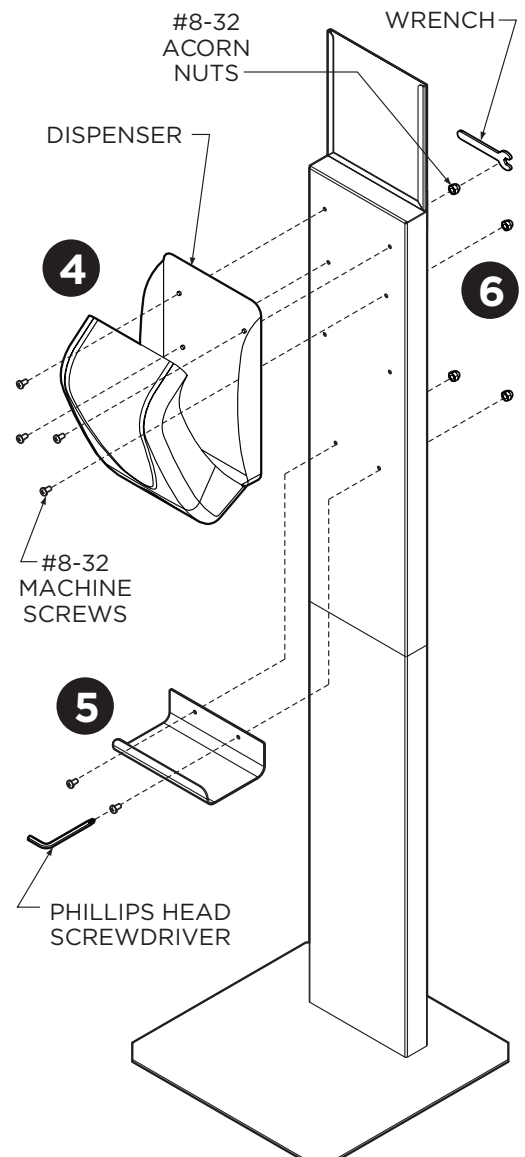

SC Johnson Professional Pty Ltd
Unit 1, 1 Secombe Place, Moorebank,
NSW 2170 Australia | T: +61 (0) 2 8763 1800

SC Johnson Professional NZ Limited
Level 8,
79 Queen Street, Auckland City,
1010, New Zealand | T: 0800 332 695

www.scjp.com

This information and all further technical advice is based upon our present knowledge and experience. However, it implies no liability or other legal responsibility on our part, including with regard to existing third party intellectual property rights, especially patent rights. In particular, no warranty, whether express or implied, or guarantee of product properties in the legal sense is intended or implied. We reserve the right to make any changes according to technological progress or further developments.

SC Johnson
PROFESSIONAL
A Family Company®